

EVERY SIP PULLS YOU IN

-  **AUTOMATIC RATIO CONTROL**
no calibration for consistent drink quality
-  **CUSTOMIZED MIXES**
custom mixes developed & updated via IOT,
24 chilled syrups & 4 ambient brands
-  **OTA BRIX UPDATES**
flavor change or new ratios without a store visit
-  **SOLD OUT FUNCTIONALITY**
automatically greys-out icon, maximizes bib use
-  **AUTOMATED CLEAN-IN-PLACE**
cleans nozzles, drain & ice chute nightly
-  **IOT CONNECTIVITY**
for diagnostics, sales data, inventory & more



newton
beverage solutions

 A MIDDLEBY COMPANY



CONTACT US

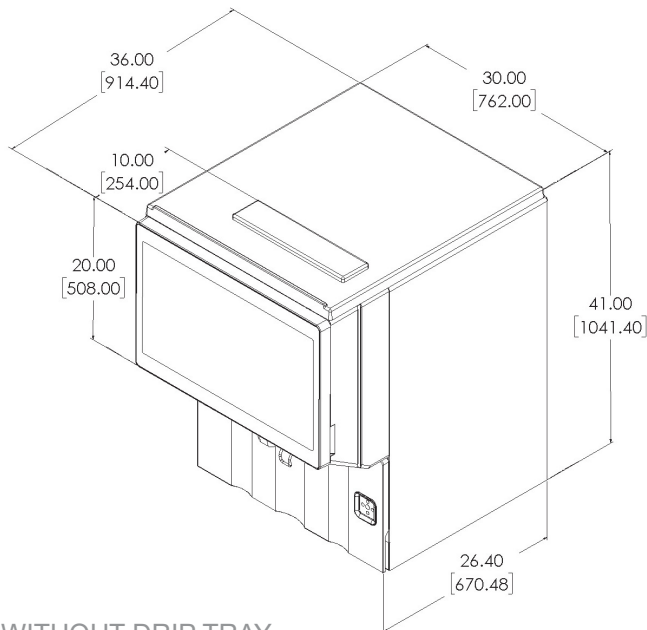

WITHOUT DRIP TRAY

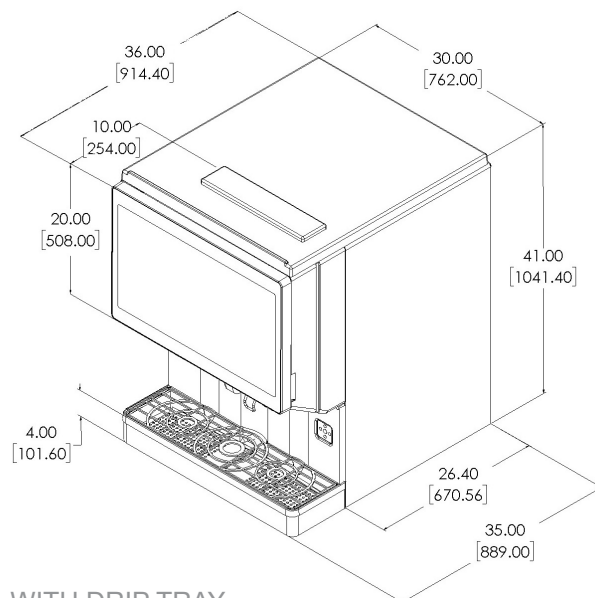

WITH DRIP TRAY

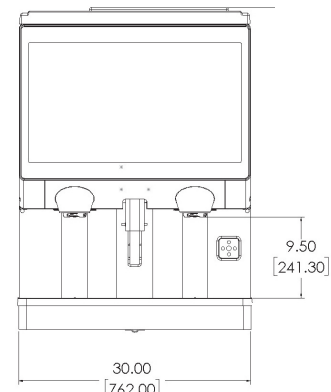
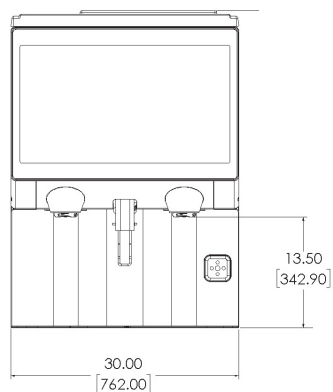

TECHNICAL SPECIFICATIONS

DIMENSIONS	41" H x 30" W x 36" D
VIDEO ASPECT RATIO	32:9
COUNTER WEIGHT	360 lb
SHIPPING WEIGHT	550 lb
ICE BIN CAPACITY	280 lbs
ELECTRICAL	115VAC / 60 Hz / 9A
OPTIONAL WATER BOOSTER	Separate plug, 115VAC/60Hz/1A
AMBIENT CARBONATOR	Separate plug, 115VAC/6.5A
FLOW RATE FOR BRANDS	3.0 oz/sec
CUP CLEARANCE	13.5" w/o Drip Tray 9.5" with Drip Tray
WATER SUPPLY PRESSURE	50-60 psi at Pump
CO₂	90-110 psi bulk to secondary CO ₂ regulator

STANDARD FEATURES

- TIMED AGITATION
- 24 CHILLED SYRUPS
- 4 AMBIENT FLAVOR SHOTS
- VALVES: CFIVE

PENDING AGENCY LISTINGS

